

FCV-09 Series Water Softener

User Manual

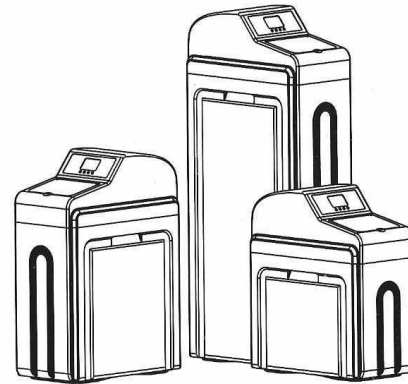

FCV-09-10/15/25(T/F)

Read through all the instructions before installing and using the unit.

Contents

Products Introduction.....	1
Components	1
Functions & Features	1
Automatic Valve Control	1
PE brine tank	2
Specifications	2
Operation	4
Cautions	5
Installation	6
Important Notices	8
Part Description	9
Automatic Control Operation Procedures	10
Meter Type	10
The Function of PC Board	10
Parameter Set	12
Basic Setting & Usage	13
Parameter Settlement	18
Parameter Enquiry and Setting	20
The Steps of Parameter Setting.....	21
Trial Running	24
Troubleshooting	26

Products Introduction

This softeners have lots of features, such as large water flux, perfect softening effect, long service life, steady running, etc. The series softeners could perfectly satisfy not only household use such as bath, washing and cleaning, but also commercial use for companies, organs and schools etc.

Components

- **Automatic Control Valve**
Noryl plastic approved by FDA;
Strong corrosion resistance, stainless;
Innovative design, refined structure;
- **Media**
High-grade Cation Exchange Resin (Food Grade)
- **FRP Vessel**
Polyethene material manufactured for the Food & Beverage industries;
Light, high pressure resistance;
Strong corrosion resistance, stainless;

Functions & Features

1. Automatic Valve Control

24 hours control and monitoring with a timer; automatically regenerate the medial bed at the system's set time of regeneration (2:00 am is the default time without setting) according to the set regeneration frequency.

Automatically calculate and design more scientific cycle plan according to the quality of supply water and the user's actual water use.

Cycle process :

IN SERV.: Supply water with suitable pressure and flow rate flows into softener, and the cations concerns to water hardness (Ca^{2+} , Mg^{2+} , etc.) in the water will

be replaced by Na^+ in regenerants, then the softening system supply softened water through its outlet.

Backwash: When the ion exchange resins are out of effect, the resin bed needs to be regenerated. And before the regeneration of resin bed, a backwash step is absolutely necessarily for two main purposes: remove the residuals and resin shatters in the resin bed, and loose the impacted resin bed for a better regeneration efficiency.

Brine: Under certain concentration and flow rate conditions, brine flow through entire resin bed, then the saturated resins will resume their softening capacity.

Rinse: Rinse the resin bed to remove the residual regenerant (salt) in it after Brine step until the water from outlet contains no regenerant; rinse could also impact the resin bed for a better softening effect.

Fill: Refill water to brine tank to dissolve salt for the next regeneration.

2. PE brine tank

Refill water and salt meet each other in the brine tank, and the salt will dissolve continuously to water through natural convection until the water is saturated by salts.

Specifications

Table 1

Model	FCV-09-10(T)	FCV-09-15(T)	FCV-09-25(T)
Control Valve	TMF-69A	TMF-69A	TMF-69A
Regeneration Frequency	3 days (Programmable)	3 days (Programmable)	3 days (Programmable)
Time of Regeneration	2:00am (Programmable)	2:00am (Programmable)	2:00am (Programmable)
Regeneration Time	Programmable	Programmable	Programmable

Model	FCV-09-10(T)	FCV-09-15(T)	FCV-09-25(T)
System Standard			
Maximum Flow Rate	0.5m ³ /hr	1.5m ³ /hr	2.5m ³ /hr
Treating Object	Municipal Water	Municipal Water	Municipal Water
Operation Pressure	0.15-0.3 MPa	0.15-0.3 MPa	0.15-0.3 MPa
Inflow Temperature Requirement	1-45°C	1-45°C	1-45°C
Transformer Input	100~240V/ 50~60 Hz	100~240V/ 50~60 Hz	100~240V/ 50~60 Hz
Transformer Output	DC12V	DC12V	DC12V
Inlet/Outlet Pipe Size	3/4 inch	3/4 inch	3/4 inch
Drain Pipe Size	φ12mm(1/2 inch)	φ12mm(1/2 inch)	φ12mm(1/2 inch)
Dimensions (L×W×H)	40*22*48 (cm)	40*22*59 (cm)	40*22*98 (cm)
Weight	≤10 kg (net, salt not included)	≤12 kg (net, salt not included)	≤21 kg (net, salt not included)

Table 2

Model	FCV-09-10(F)	FCV-09-15(F)	FCV-09-25(F)
Control Valve	TMF-69A3	TMF-69A3	TMF-69A3
Regeneration Frequency	10m ³ (Programmable)	10m ³ (Programmable)	10m ³ (Programmable)
Time of Regeneration	2:00am (Programmable)	2:00am (Programmable)	2:00am (Programmable)
Regeneration Time	Programmable	Programmable	Programmable
System Standard			
Maximum Flow Rate	0.5m ³ /hr	1.5m ³ /hr	2.5m ³ /hr
Treating Object	Municipal Water	Municipal Water	Municipal Water
Operation Pressure	0.15-0.3 MPa	0.15-0.3 MPa	0.15-0.3 MPa
Inflow Temperature Requirement	1-45°C	1-45°C	1-45°C
Transformer Input	100~240V/ 50~60 Hz	100~240V/ 50~60 Hz	100~240V/ 50~60 Hz

Model	FCV-09-10(F)	FCV-09-15(F)	FCV-09-25(F)
Transformer Output	DC12V	DC12V	DC12V
Inlet/Outlet Pipe Size	1/2 inch	1/2 inch	1/2 inch
Drain Pipe Size	φ10mm	φ10mm	φ10mm
Dimensions (L×W×H)	40*22*48 (cm)	40*22*59 (cm)	40*22*98 (cm)
Weight	≤10 kg (net, salt not included)	≤12 kg (net, salt not included)	≤21 kg (net, salt not included)

Operation

This product should be able to put in normal use right after the complete installation and a regeneration test; any other operations are not necessary unless power supply is cut off accidentally;

1. The soften unit should be installed and prepared by qualified person, any other operations are not necessary while keeping power on all the time and remaining enough salt in brine tank. The only requirements for installation are three water pipe ports (inlet, outlet, drain) and power supply.
2. Fill resin tank with water (Initial)
 - Set the control into the backwash position, then open water supply valve very slowly to approximately the 1/4 open position and let water flow slowly into the resin tank (If open too rapidly or too far, resin may be lost). When all of the air has been purged from the tank (water begins to flow steadily from the drain), open the main supply valve to the full position.
 - Drain until the drain water is clear.
 - Shut off water supply and let the unit stand for about five minutes to escape all trapped air from the tank.
3. Refill brine tank
 - Manually initiate a whole regeneration cycles after resin tank filling (see Appendix) to fill appropriate water to brine tank.
 - Salt level should be higher than water level at first time. There should be enough solid salt at anytime.

4. It is recommended to install a bypass system to ensure water supply in any special cases, such as softener failure, maintenance, etc.

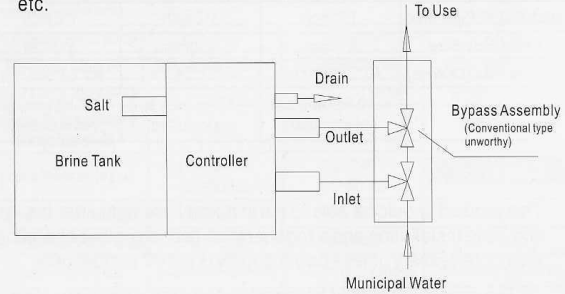

Bypass Assembly Installation Schematic Figure

Cautions

- Without reading and truly understanding the contents of this user manual, please **DO NOT** perform any operations on the control valve.
- Strictly prohibit leaning position when shipping, installing and using this product. Otherwise, it will be damaged inside.
- During regeneration time, water from tap will **NOT** be softened. It is **NOT** recommended to use water during regeneration; otherwise, a negative effect on the regeneration result will occur.
- Initial a regenerate cycle after being inactivated in a long period of time, and then turn on the tap for several minutes before resuming normal use.
- **DO NOT** disconnect power during service time to keep the timer run normal that controls the regeneration function.
- If water usage or hardness of raw water dramatically increases (comparing to the normal usage), the frequency of regeneration should correspondingly increase.

5

- Hot water could cause severe damage to the softener system; for water boiler and water heater users, ensure the total-run of the piping between the softener and the boiler is not less than 3 meters; it is recommended to install a check valve between the filter and the boiler if unable to meet the required piping length. The required environmental temperature for softener is 34-100 °F . Please protect the softener from frozen.
- **DO NOT** apply any pressure on the filter; avoid exposure to direct sun light and radiation from other heating sources.

Installation

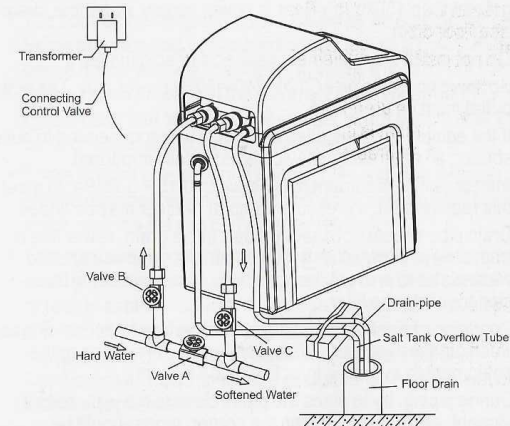

Instructions: Install three ball valves to connect the control valve and inlet/outlet pipeline. The valve B is connected with the inlet of the control valve; the valve C is connected with the outlet of the control valve. When repair the tank, please open the valve A and close the valve B and valve C; When normally use, please close the valve A and open the valve B and valve C.

6

- Control valve should be higher than sewer. The drain line and overflow line shouldn't exceed two meters and also be higher than sewer. The cut-off equipment is forbidden to be mounted on the drain line. The materials that used for pipe sealing only can be PTEF.
- Each pipeline should be supported with fixed holder independently, avoiding the control valve be damaged by bearing the gravity from the pipeline.

Installation

- Selected ground should be level; minimum support should be greater than 150kg/m²; Near to power supply, water line, drain and floor drain.
- Do not install the equipment near acid or acid fumes.
- Softener operates on AC120~240V/50Hz power only. The power outlet must be grounded.
- If the equipment is installed outdoor, it is recommended to build a shelter; an antifreezing device is especially important.
Inlet pressure requirement is between 0.15 ~ 0.3MPa; to meet this requirement, a pressure pump or reducer may be added.
- Drain pipe should not directly insert into a drain, sewer line or trap; always allow an air gap between the drain line and the wastewater to prevent the possibility of sewage being back-siphoned into the filter.
- Condition of existing plumbing should be free from dust. Please wash out the inner part of the pipe before connecting to the equipment to avoid the infection of the system.
- During piping, try to place the pipes close to the wall, keep it straight, and bend clearly on the corner; pipes should be attached on the wall after completing the piping.
- When connecting the pipe to the equipment, please pay attention to the adapting height and angle; there should not be much of tensions at the joint; otherwise, such tension may damage the pipes in a long period of time and causing leaking from the equipment or pipes.

- When joining components, be sure not to apply too much pressure on them to avoid damaging the screw.
- Connect one end of the regenerant line to the brine port on the valve, insert another end into the hole on the brine well cover till bottom. Make the connections and hand tighten, be sure that the regenerant line is secure and free from air leaks.
- Insert overflow fitting into tank and attach drain tubing to it. Overflow line must be a direct separate line from overflow fitting to drain. Allow an air gap as per drain line instructions.

Important Notices

- The controlling components are driven by an electric circuit. Some programmed parameters will be lost as a power outage over 8 hours, and water softener systems will carry out the regeneration process at the incorrect time. We strongly recommend that after a power outage, users should check the timer or adjust it according to the Appendix.
- There is extra one set white suction pipe with this softener, please replace it when the Salt and white suction pipe ageing or crack, and the old one could not be reused.
- This appliance is not intended for use by persons (including children) with reduced physical, sensory or mental capabilities, or lack of experience and knowledge, unless they have been given supervision or instruction or instruction concerning use of the appliance by a person responsible for their safety. Children should be supervised to ensure that they do not play with the appliance.

NOTE System technology and specification data may change without notice. Please refer to the latest information. Sorry for the inconvenience.

Part Description

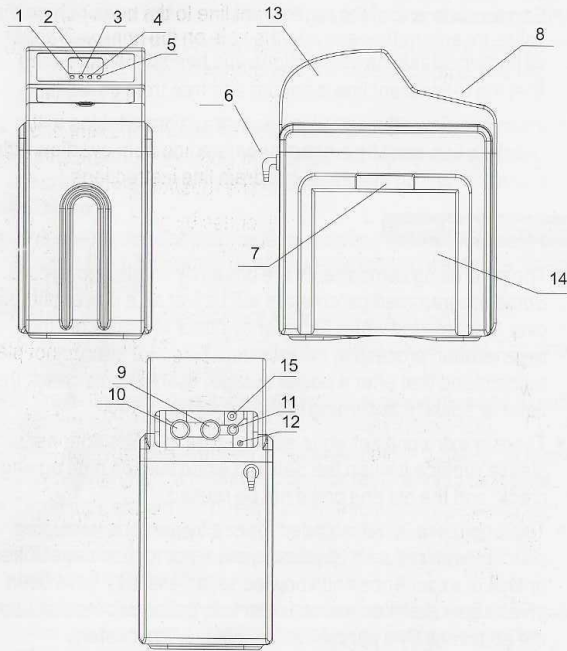

1. Menu/Confirm Buttons	5. UP Buttons	9. Water Outlet	13. Cover Part
2. Show Screen	6. Overflow Mouth	10. Water Inlet	14. Case Part
3. Manual/Return Buttons	7. Handle	11. Drain Outlet	15. Brine Line Connector
4. Down Buttons	8. Flip Part	12. Two Cores Socket	

9

Appendix : Automatic Control Operation Procedures

◎ Meter Type

Model	Name	Instruction
A-01	Meter Delayed	Regenerate on the day although the available volume of treated water drops to zero(0).Regeneration starts at the regeneration time
A-02	Meter Immediate	Regenerate immediately when the available volume of treated water drops to zero(0).
A-03	Intelligent Meter Delayed	Meter Delayed Regeneration type, but by setting Resin Volume, Feed Water Hardness, Regeneration Factor, the controller will calculate the System Capacity
A-04	Intelligent Meter Immediate	Meter Immediate Regeneration type, but by setting Resin Volume, Feed Water Hardness., Regeneration Factor, the controller will calculate the System Capacity

◎ The Function of PC Board

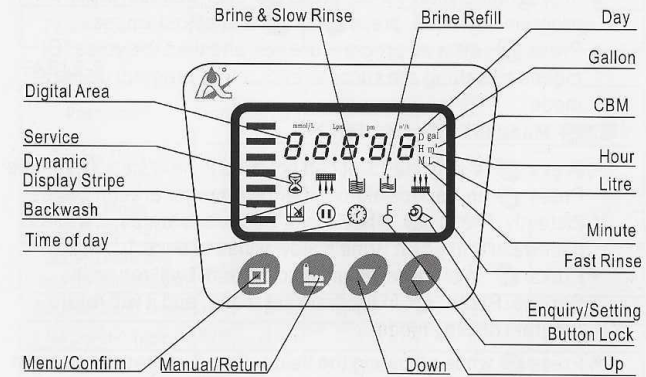

10

A. ☀ Time of day indicator

- ☀ Light on, display the time of day
- "12:12" flash, remind you to reset the time of day if electrical service interrupted 3 days more (If electrical service interrupted within 3 days, it doesn't need to reset the time.)

B. 🔒 Button lock indicator

- 🔒 Light on, indicate the buttons are locked. At this moment, press any single button will not work (No operation in one minute, 🔒 will light on and lock the buttons.)
- Solution: Press and hold both ⏴ and ⏵ for 5 seconds until the 🔒 light off.

C. 🔄 Program mode indicator

- 🔄 Light on, enter program display mode. Use ⏴ or ⏵ to view all valves.
- 🔄 Flash and enter program set mode. Press ⏴ or ⏵ to adjust values.

D. 🗄 Menu/Confirm button

- Press 🗄, 🔄 light on, enter program display mode and use ⏴ or ⏵ to view all values.
- In program display mode, press 🗄, 🔄 flashes, enter program set mode, press ⏴ or ⏵ and adjust values.
- Press 🗄, after all program are set, and then the voice "Di" means all setting are success and return program display mode.

E. ⏴ Manual/Return button

- Press ⏴ in any status, it can proceed to next step. (Example: Press ⏴ in Service status, it will start regeneration cycles instantly; Press ⏴ while it is in Backwash status, it will end backwash and go on Brine & Slow Rinse at once.)
- Press ⏴ in program display mode, and it will return in Service. Press ⏴ in program set mode, and it will return program display mode.
- Press ⏴ while adjusting the value, then it will return program display mode directly without saving value.

F. Down ⏴ and up ⏵

- In program display mode, press ⏴ or ⏵ to view all values.
- In program set mode, press ⏴ or ⏵ to adjust values.
- Press and hold both ⏴ and ⏵ for 5 seconds to lift the Button Lock status.

Ⓞ Parameter set/

TABLE 1

Parameter	Unit	Default	Actual		
			FCV-09-10(T)	FCV-09-15(T)	FCV-11-25(T)
Control Mode A-01(02,03,04)	/	A-01	A-01	A-01	A-01
Unit Mode HU01(02,03)	/	HU01	HU01	HU01	HU01
Service Days(Time clock type,by days)	D	20	20	25	30
Regeneration Time	/	0	0	0	0
Backwash Time	MIN	1	5	6	8
Brine & Slow Rinse Time	MIN	40	15	20	30
Brine Refill Time	MIN	1	1	1.5	2
Fast Rinse Time	MIN	1	5	6	8

TABLE 2

Parameter	Unit	Default	Actual		
			FCV-09-10(F)	FCV-09-15(F)	FCV-09-25(F)
Control Mode A-01(02,03,04)	/	A-01	A-01	A-01	A-01
Unit Mode HU01(02,03)	/	HU01	HU01	HU01	HU01
Water Treatment Capacity(Meter type)	m ³	12	10	14	18
Regeneration Time	/	0	0	0	0
Backwash Time	MIN	1	1	1	8
Brine & Slow Rinse Time	MIN	40	40	50	30

Parameter	Unit	Default	Actual		
			FCV-09-10(F)	FCV-09-15(F)	FCV-09-25(F)
Brine Refill Time	MIN	1	1	1.5	2
Fast Rinse Time	MIN	1	1	1	8



NOTE:

Please make sure the data displayed is same with the set value in the table before starting the machine. If it is unconformity, please follow the steps below to set the value required.

© Basic Setting & Usage

A. Parameter specification

Function	Indicator	Factory Default	Parameter Set Ranger	Instruction
Time of Day		Random	00:00~23:59	Ser the time of day when use, ":" flash
Control Mode	A-01	A-01	A-01	Meter Delayed: Regenerate on the day although the available volume of treated water drops to zero(0). Regeneration starts at the regeneration time.
			A-02	Meter Immediate : Regenerate immediately when the available to volume of treated water drops to zero(0).
			A-03	Intelligent Meter Delayed: Meter Delayed Regeneration type, but by setting Resin Volume, Feed Water Hardness, Regeneration Factor, the controller will calculate the System Capacity.

Function	Indicator	Factory Default	Parameter Set Ranger	Instruction
Control Mode	A-01	A-01	A-04	Intelligent Meter Immediate: Meter Delayed Regeneration type, but by setting Resin Volume, Feed Water Hardness, Regeneration Factor , the controller will calculate the System Capacity.
Unit Mode	HU-01	HU-01	01,02,03	01-m ³ ;02-gal;03-L
Service Days		1-03D	0~99Days	Only for Time Clock Type, regeneration by hours
Service Hours		1-20H	0~99Hours	Only for Time Clock Type, regeneration by hours
Regeneration time	02:00	02:00	00:00~23:59	Regeneration time; ":" light on
Interval backwash times	F-00	00	0~20	Interval backwash times. For example, F-01: indicate service 2 times, backwash 1 time
Resin volume	20L	20L	5~500L	Resin volume in resin tank(L)
Feed Water Hardness	Yd1.2	1.2	0.1~9.9	Feed water hardness(mmol/L)
Exchange Factor	AL.65	0.65	0.30~0.99	Relate to the raw water hardness. When hardness is higher, the factor is smaller.
Water Treatment Capacity		10m ³	0~99.99m ³	Water treatment capacity in one circle(m ³)

Function	Indicator	Factory Default	Parameter Set Ranger	Instruction
Backwash Time		10min.	0~99.59	Backwash time(Minute)
Brine & Slow Rinse Time		60min	0~99.59	Brine & slow rinse time(Minute)
Brine Refill Time		5min.	0~99.59	Brine refill time(Minute)
Fast Rinse Time		10min.	0~99.59	Fast rinse time(Minute)
Maximum Interval Regeneration Days	H-30	30	0~40	Regenerate on the day even through the available volume of treated water does not drop to zero(0).
Output Control Mode	b-01	01	01 or 02	Mode 01:Signal turn on start of regeneration and shut off end of regeneration.(Connection refer to the Figure P6)Mode 02:Signal available only intervals of regeneration cycles and in service.(Connection refer to the Figure P6)

B. Process Display

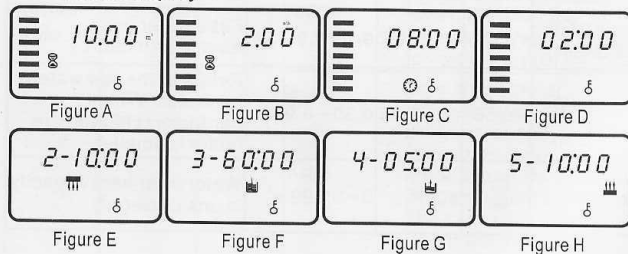

Instruction

- In Service status, the figure shows A/B/C/D; In Backwash status, it shows figure E/C; In Brine & Slow Rinse status, it shows F/C; In Brine Refill status, it shows figure G/C; In Fast Rinse status, it shows figure H/C. In each status, every figure shows 15 seconds.
- Above displays are taking the Meter Type for example. For the Time Clock Type, it shows the rest day or hours, such as 1-03D or 1-10H.
- The display screen will only show "-00-" when the electrical motor is running.
- The time of day figure "🕒" flashes continuously, such as "12:12" flashes, indicates long outage of power. It reminds to reset the time of day.
- The display will show the error code, such as "-E1-" when the system is in error.
- Working process: Service → Backwash → Brine & Slow Rinse → Brine Refill → Fast Rinse → Service

C. Usage

After being accomplished installation, parameter setting and trial running, the valve could be put into use. In order to ensure the quality of outlet water can reach the requirement, the user should complete the below works:

- ① Ensure that there is solid salt all the time in the brine tank in the course of using when this valve is used for soften. The brine tank should be added the clean water softening salts only, at least 99.5% pure, forbidding use the small salt and iodized salt.
- ② Test the outlet water and raw water hardness at regular time. When the outlet water hardness is unqualified, please press the 🕒 and the valve will temporary regenerate again (It will not affect the original set operation cycle)
- ③ When the feed water hardness change a lot, you can adjust the water treatment capacity as follow:

- Press and hold both \odot and \odot for 5 seconds to lift the lock status. Press \odot , and the \odot light on, then press \odot , the digital area show the control mode. If it shows A-01 or A-02, press three times, and the digital area will show the given water treatment capacity (If the control mode shows A-03 or A-04, then press \odot four times, the digital are will show the feed water hardness); Press \odot again, \odot and digital flash. Press \odot or \odot continuously, reset the capacity value (Or water hardness). Press \odot and hear a sound "Di" then finish the adjustment. Press \odot exit and turn back the service status.

- The estimation of water treatment capacity, you can refer to the professional application specification. When select A-03 or A-04 intelligent control mode, the control will automatically calculate the water treatment capacity by setting resin volume, feed water hardness and regeneration factor.

- ④ For A-01 or A-03 control mode (Delayed regeneration type), please pay attention to whether the time is current or not. If the time is not right, you can adjust as follow: After lifting the lock status, press \odot , the \odot and " \odot " light on. Then press \odot , the \odot and hour value flash. Press \odot or \odot continuously, reset the hour value; Press \odot again, \odot and minute value flash. Press \odot or \odot continuously, reset the minute value; Press \odot and hear a sound "Di", then finish the adjustment. Press \odot exit and turn back the service status.

The regeneration parameters have been when control value left factory. Generally, it does not need to reset. If you want enquiry and modify the setting, you can refer to the professional application specification.

◎ Parameter Settlement

① Service time T1

Water treatment capacity

$$Q = V_R \times K + Y_0 \text{ (m}^3\text{)}$$

Hardness of inlet water (mmol/L)

Exchange factor (mmol/L) 400~1000.

Down-flow regeneration, take 400~750.

Up-flow regeneration, take 450~750.

If the inlet water hardness is higher, the factor is smaller.

Resin volume (m³)

By hours: $T1 = Q + Q_h$ (Hour)

Water treatment capacity per hour (m³/h)

Water treatment capacity (m³)

By hours: $T1 = Q + Q_d$ (Day)

Water treatment capacity per day (m³/h)

Water treatment capacity (m³)

② Backwash time T2

It is subject to the turbidity of inlet water. Generally, it is suggested to be set 10~15 minutes. The higher the turbidity is, the longer backwash time can be set. However, if the turbidity is more than 5FTU, it should be better to install a filter in front of the exchanger.

③ Brine & Slow Rinse Time T3

$$T3 = (40 \sim 50) \times H_R \text{ (min)}$$

Generally, $T3 = 45 H_R$ (min)

In this formula, H_R —The height of resin in exchange tank (m)

④ Brine Refill Time T4

Down-Flow Regeneration : $T4 = 0.45 \times V_R + \text{Brine Refill Speed (min)}$

Up-Flow Regeneration : $T4 = 0.34 \times V_R + \text{Brine Refill Speed (min)}$

In this formula, V_R —Resin volume(m^3)

The Brine Refill Speed is related to inlet water pressure. It is suggested to lengthen 1~2 minutes of calculated brine refilling time to make sure there is enough water in tank.(The condition is that there is a level controller installed in the brine tank)

⑤ Fast rinse time T5

$$T5=12 \times H_R(\text{min})$$

Generally, the water for fast rinse is 3~6 times of resin volume. It is suggested to be set 10~16 minutes, but subject to the outlet water reaching the requirement.

⑥ Exchange factor

$$\text{Exchange factor} = E / (k \times 1000)$$

In this formula, E—Resin working exchange capability(mol/m^3), it is related to the quality of resin. Down-flow regeneration, take 800~900. Up-flow regeneration, take 900~1200.

K—Security factor, always take 1.2~2. It is related to the hardness of inlet water: the higher the hardness is, the bigger the K is.

⑦ Set up interval backwash times(Only for F69)

When the turbidity of raw water is higher, the interval backwash time could be set F-00. That is, backwash in each regeneration; When the turbidity is lower, the interval backwash time could be set F-01(Or other number value), it is to say that backwash in every two regeneration. Thus, Service→Brine&Slow Time→Brine Refill→Fast Rinse→Service→Backwash→Brine&Slow Rinse→Brine Refill→Fast Rinse.

⑧ Regeneration Time :

The whole cycle for generation is about two hours. Please try to set up the regeneration time when you don't need water according to the actual situation.

The calculation of parameters for each step is only for reference, the actual proper time will be determined after adjusting by water exchanger supplier. This calculation procedure of softener is only for industrial application; It is not suitable for small softener in residential application.

◎ Parameter Enquiry and Setting

Parameter Enquiry

When δ light on, press and hold both \odot and \odot for 5 seconds to lift the button lock statuses; then press \odot and \odot light on, enter to program display mode; press \odot or \odot to view each value according to below process.(Press \odot exit and turn back to service status)

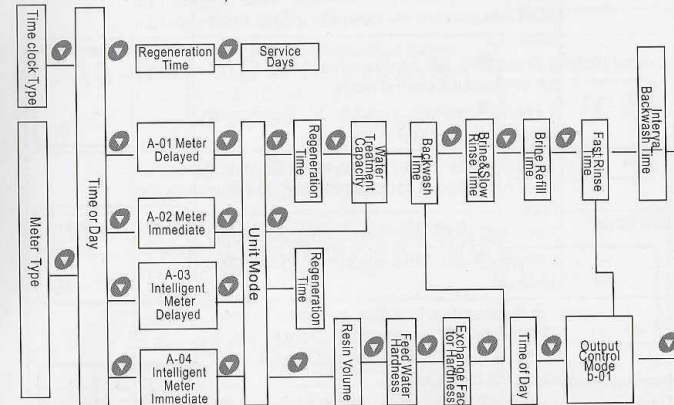

Attention: For the F69 valve, after enquiry "Unit Mode" or "Regeneration Time", it will show "F-00", which indicates the interval backwash times.

Parameter Setting

In program display mode, press \odot and enter into program set mode. Press \odot or \odot to adjust the value.

© The steps of parameter setting

Items	Process steps	Symbol
Time of Day	When time of day "12:12" continuously flash, it reminds to reset; 1. Press to enter into program display mode; both and symbol light on, ":" flicker; Press , both and hour value flash, through or to adjust the hour value; 2. Press again, both and minute value flash, through or to adjust the minute value; 3. Press and hear a sound "Di", then finish adjustment, press to turn back.	
Control Mode	1. In control mode display status, press and enter into program set mode, and 01 value flash; 2. Press or , set the value to be A-01, A-02, A-03 or A-04 control mode; 3. Press and hear a sound "Di", then finish adjustment, press to turn back.	
Unit Mode	1. In unit mode display status, press and enter into program set mode, and 01 value flash; 2. Press or , and choose from the m ³ /l/gal; 3. Press and finish adjustment, press to turn back.	
Regeneration Time	1. In regeneration time display status, it shows 02:00; Press and enter into program set mode; and 02 flash; Press or to adjust the hour value; 2. Press again, and 00 flash, press or to adjust the minute value; 3. Press and hear a sound "Di", then finish adjustment, press to turn back.	

Items	Process steps	Symbol
Interval Backwash Times	1. In interval backwash time display status, it shows F-00; Press and enter into program set mode; and 00 value flash; 2. Press or to adjust the interval backwash times value; 3. Press and hear a sound "Di", then finish adjustment, press to turn back.	
Water Treatment Capacity	1. In water treatment capacity display status, it shows and 10.00. Press and enter into program set mode; and 10.00 flash; 2. Press or to adjust the water treatment capacity value(m ³); 3. Press and hear a sound "Di", then finish adjustment, press to turn back.	
Resin Volume	1. In Resin Volume display status, it shows 1000L. Press and enter into program set mode; and 100 value flash; 2. Press or to adjust the Resin Volume value(L); 3. Press and hear a sound "Di", then finish adjustment, press to turn back.	
Feed Water Hardness	1. In Feed Water Hardness display status, it shows yd1.2. Press and enter into program set mode; and 1.2 value flash; 2. Press or to adjust the Water Hardness value(mmol/L); 3. Press and hear a sound "Di", then finish adjustment, press to turn back.	
Exchange Factor	1. In Exchange Factor display status, it shows AL.55. Press and enter into program set mode; and 55 flash; 2. Press or to adjust the Exchange Factor value; 3. Press and hear a sound "Di", then finish adjustment, press to turn back.	

Items	Process steps	Symbol
Backwash Time	1. In Backwash Time display status, it shows and 2-10:00. Press and enter into program set mode; and 10:00 flash; 2. Press or to adjust the Backwash Time(minute); 3. Press and hear a sound "Di", then finish adjustment, press to turn back.	
Brine & Slow Rinse Time	1. In Brine & Slow Rinse Time display status, it shows and 3-60:00. Press and enter into program set mode; and 60:00 flash; 2. Press or to adjust the Brine & Slow Rinse Time(minute); 3. Press and hear a sound "Di", then finish adjustment, press to turn back.	
Brine Refill Time	1. In Brine Refill Time display status, it shows and 4-10:00. Press and enter into program set mode; and 05:00 flash; 2. Press or to adjust the Brine Refill Time(m ³); 3. Press and hear a sound "Di", then finish adjustment, press to turn back.	
Fast Rinse Time	1. In Fast Rinse Time display status, it shows and 5-10:00. Press and enter into program set mode; and 10:00 flash; 2. Press or to adjust the Fast Rinse Times(minute); 3. Press and hear a sound "Di", then finish adjustment, press to turn back.	
Maximum Interval Regeneration Days	1. In Maximum Interval Regeneration Days display status, it shows H-30. Press and enter into program set mode; and 30 flash; 2. Press or to adjust the water treatment capacity value(m ³); 3. Press and hear a sound "Di", then finish adjustment, press to turn back.	

Items	Process steps	Symbol
Signal Output Mode	1. In Signal Output Mode display status, it shows b-01. Press and enter into program set mode; and 01 flash; 2. Press or to adjust the b-02; 3. Press and hear a sound "Di", then finish adjustment, press to turn back.	











For example, the fast rinse time of a softener is 12 minutes. After regenerating, the chloridion in the outlet water is always higher than normal, indicating that there is not enough time for fast rinse. If you want the time to set to 15 minutes, the modification steps as follows:

- ① Press and hold both and to lift the button lock statues (light off);
- ② Press and light on;
- ③ Press or continuously until light on. Then the digital area shows:5-12M;
- ④ Press and "12" flash;
- ⑤ Press continuously until "12" changed to "15"
- ⑥ Press , there is a sound "Di" and the figure stop flashing; the program back to enquiry status;
- ⑦ If you want to adjust other parameters, you can repeat the steps from ② to ⑤; If you don't, press and quit from the enquiry stat, the display will show the current service status.

© Trial Running

After intalling the multi-function flow control valve on the resin tank with the connected pipes, as well as setting up the relevant parameter, please conduct the trail running as follows:

- A. Close the inlet valve B & C, and open the bypass valve A. After cleaning the foreign materials in the pipe, close the bypass valve A. (As Figure 1-3 shows)
- B. Fill the brine tank with the planned amount of water and adjust the air check valve. Then add solid salt to the tank and dissolve the salt as much as possible.

- C. Switch on power. Press  and go in the Backwash position; when  light on, slowly open the inlet valve B to 1/4 position, making the water flow into the resin tank; you can hear the sound of air-out from the drain pipeline. After all air is out of pipeline, then open inlet valve B completely and clean the foreign materials in the resin tank until the outlet water is clean. It will take 8~10 minutes to finish the whole process.
- D. Press , turning the position from Backwash to Brine & Slow Rinse;  light on and enter in the process of Brine& Slow Rinse. The air check valve close when control valve finished sucking brine, then slow rinse to work. It is about 60~65 minutes for whole process.
- E. Press  to Brine refill position.  light on and it indicates the brine tank is being refilled with water to the required level. It takes about 5~6 minutes, then add solid salt
- F. Press , turning to Fast Rinse position.  light on and start to fast rinse. After 10~15 minutes, take out some outlet water for testing: if the water hardness reach the requirement, and the chloridion in the water is almost the same compared with the inlet water, then go to the next step.
- G. Press , making the control valve return to Service Status;  light on and start to running.

Note:

When the control valve enters into the regeneration status, all program can be finished automatically according to the setting time; if you want one of steps terminated early, you can press .

If water inflow too fast, the media in tank will be damaged. When water inflow slowly, there is a sound of air emptying from drain pipeline.

After changing resin, please empty air in the resin according to the above **Step C**.

In the process of trail running, please check the water situation in all position, ensuring there are no resin leakage.

The time for Backwash, Brine&Slow Rinse, Brine Refill and Fast Rinse position can be set and executed according to the calculation in the formula or suggestions from the control valve suppliers.

Troubleshooting

Problem	Possible Cause	Solution
Controller does not work	1. Transformer is not plugged in 2. Defective power cord 3. Power off 4. Defective transformer	1. Connect to constant power source 2. Replace cord 3. Just wait for power on 4. Replace the transformer
Incorrect Time of Regeneration	Power outage causes inaccurate timing	According to the User Manual to reset the timer
Leaking	Loose connecting	Tighten joints
Noisy	Air exists in the system	Re-backwash the system to vent air
Milk-white water	Air exists in the system	Turn on the tap to vent air
Unsatisfied water hardness	1. Poor raw water quality 2. Time of regeneration is too long 3. Resin disabled	1. Call your dealer 2. Reset time of regeneration 3. Initial a manual regeneration cycle
Softener fails to use salt	1. Water pressure is too low; 2. Brine line plugged; 3. Injector is plugged; 4. Internal control leak.	1. Line pressure must be at least 20 psi; 2. Clean brine line; 3. Clean or replace injector and screen; 4. Check piston, seals and spacers
Brine container overflow	Refill time disordered	Call your dealer

Problem	Possible Cause	Solution
Water hardness remains Control backwashes at excessively low or high rate	1. Fail to regenerate automatically	1. Check power of controller
	2. Brine concentration is poor	2. Keep brine tank full of salt
	3. Injector is plugged	3. Clean or replace injector and screen
	1. Incorrect backwash controller used.	1. Replace with correct size controller.
	2. Foreign matter affecting controller operation.	2. Remove controller and ball. Flush with water.
Untreated water leakage during service	1. Improper regeneration.	1. Repeat regeneration making certain that the correct salt dosage is set.
	2. Leaking of bypass valve.	2. Replace O-ring.
	3. O-ring around riser tube damaged.	3. Replace O-ring.
	4. Incorrect regeneration cycle setting	4. Reset regeneration cycle.